

## Exhaust Tip/Cover Installation

### Full Assembly

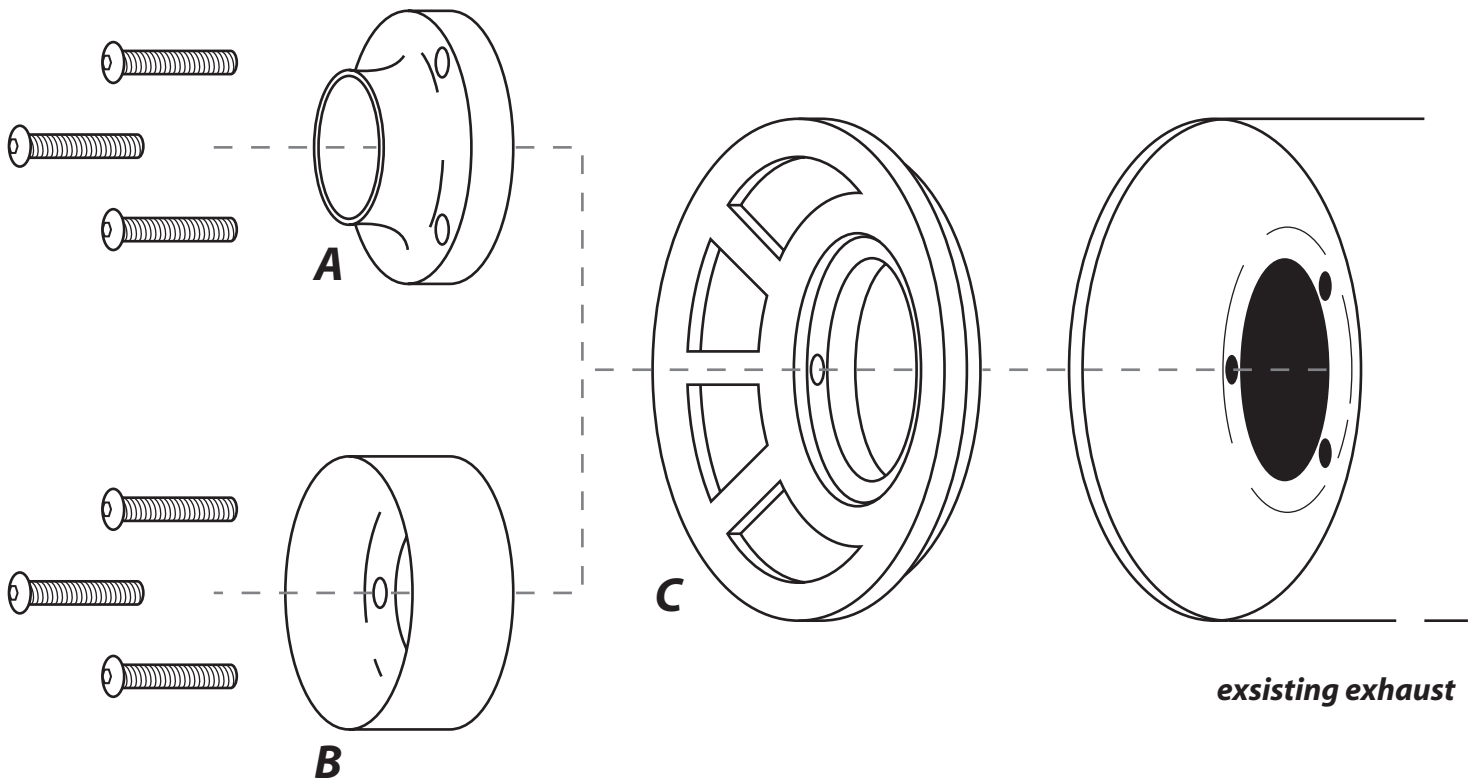

**A** part #45950 - 2.25" Rhino Exhaust Tip  
**B** part #45960 - 3.5" Rhino Exhaust Tip  
**C** part # 45970 - Exhaust Cover

### Hardware Included

Part **A** or **B**

• 3 - 6 mm x 20 BHCS SS  
allen screws

Part **C**

• 3 - 6 mm x 35 BHCS SS  
allen screws

### Tools Required

• metric allen wrench set

*Note: Make sure to use anti-seize on all bolts before installation*

# Rhino Exhaust Installation

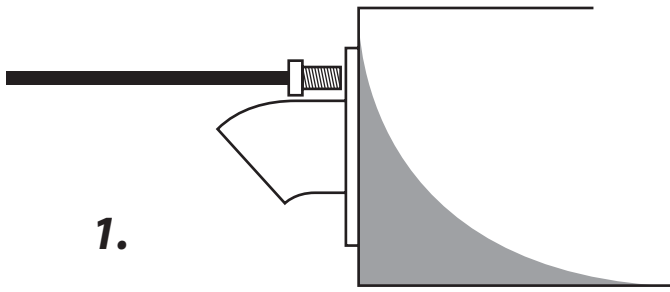

1.

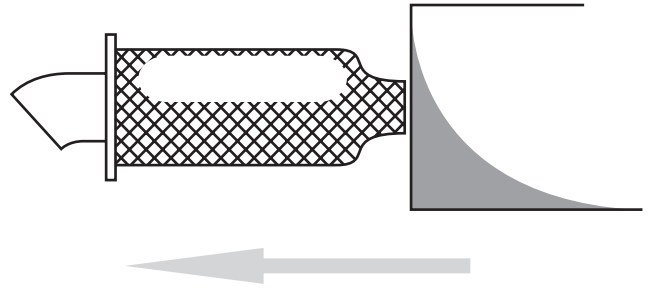

2.

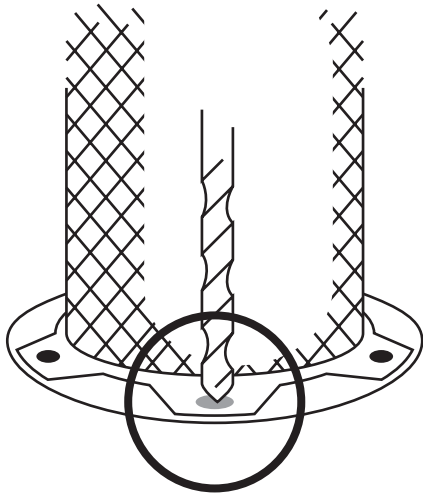

3.

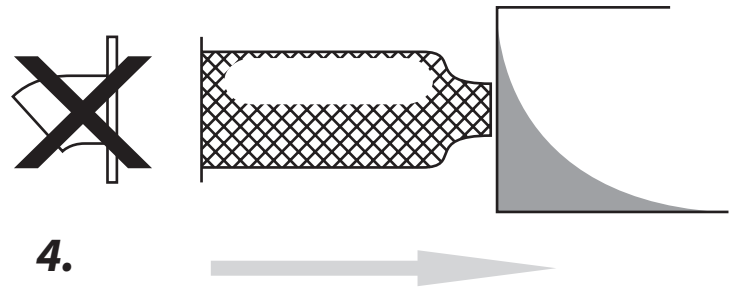

4.



5.

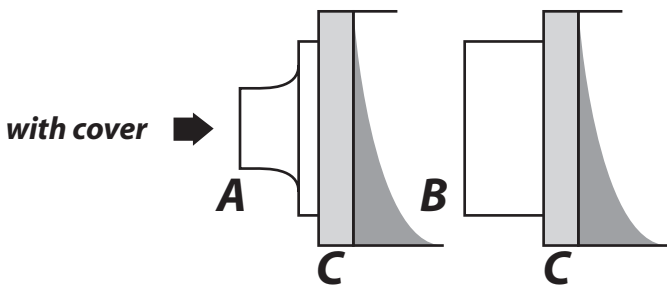

## Diagram A

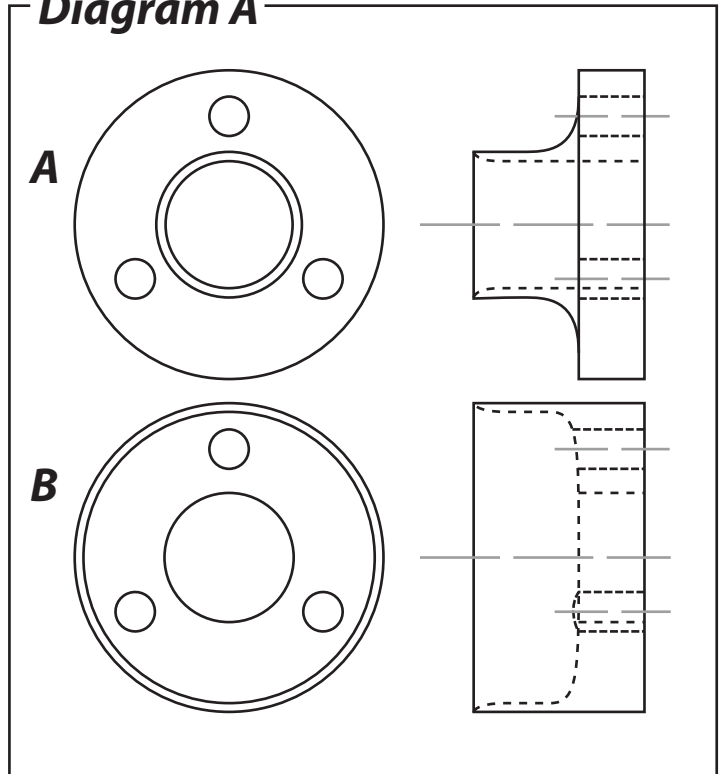

1. Remove Cap Screws.
2. Remove Spark Arrestor Filter.
3. Drill out spot weld and remove exhaust tip.
4. Place filter back in exhaust. Discard old exhaust tip.
5. Put on Speed Ind. Exhaust Tip and optional Cover with provided screws. *Be sure to grease screws before install.*

Note :There are two styles of exhaust tips (**A** and **B**). Refer to **Diagram A** for differences.  
The Cover (**C**)is an optional piece when buying the Exhaust Tip,  
this does not come standard with Exhaust Tip.